



AIRTIGHTNESS & MOISTURE CONTROL SOLUTIONS

Vario® Airtightness & Moisture
Control System – The Complete
Intelligent System

CONTENTS

| | |
|--|----|
| Introduction | 3 |
| How does the Vario® membrane work? | 4 |
| Where should you use Vario®? | 5 |
| A quick guide to the Vario® system..... | 8 |
| Building Regulations | 10 |
| Isover Vario® System..... | 12 |
| Attics..... | 14 |
| Pitched Roofs..... | 15 |
| Pitched Roof with Internal Counter Battens | 16 |
| Dry Lining | 18 |
| Timber Frame Wall..... | 20 |
| Metal Stud Separating Party Wall..... | 22 |
| Suspended Ground Floor | 23 |
| Case Study | 24 |



AIRTIGHTNESS & MOISTURE CONTROL VARIO® SYSTEM

A range of high performance membranes with accompanying accessories, unique in providing excellent levels of airtightness with unparalleled protection against moisture. A well sealed ceiling is a requirement of most agrément certificates for breathable roofing felts, essential to future proof all buildings.

What is Vario®?

Vario® System consists of two intelligent membranes, accessory tapes and a sealant, designed to adapt to the climate and protect your building, inside and out. The system is also designed with an uncompromising commitment to superior airtightness. Vario® System meets and exceeds industry standards, while making a substantial contribution to your BER, reducing the environmental footprint of the building.

The Vario® system is a high performance system consisting of intelligent membranes and accessory products and provides;

- ✓ Excellent levels of airtightness within the building envelope
- ✓ Protection against moisture by facilitating the drying of the building structure
- ✓ Variable S_d value and can diffuse 25 more times more moisture in summer than the structure absorbs in winter

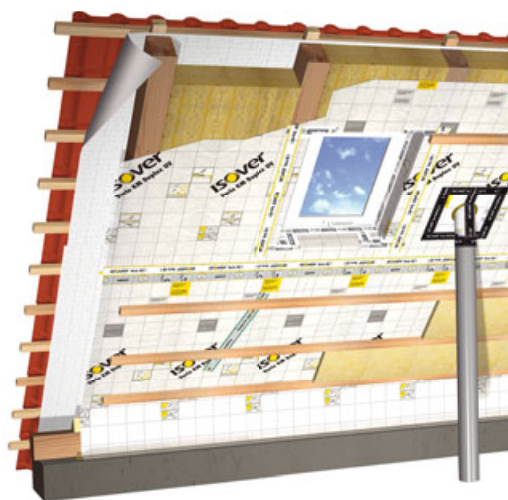

Where to use



Residential



Non Residential



Airtightness & Moisture Control



Membrane Performance Overview

Materials: Modified fabric-reinforced polyamide faced with a special polypropylene fabric

Water vapour transmission: $0,3 \leq S_d \leq 5$ (KM Duplex) $0,3 \leq S_d \leq 20$ (Xtra)

Water Vapour Resistance: 1.5 - 25 MNS/g / 1.5 - 100 MNS/g

Maximum tensile strength: ≥ 110 N/50 mm

Nail tear Resistance: ≥ 50 N (KM Duplex) ≥ 40 N (Xtra)

Temperature range: - 40°C to + 80°C



BENEFITS AND FEATURES

| | |
|--------------------------|--|
| ✓ THERMAL | Creates an airtight barrier to lock out draughts and keep in heat. Excellent thermal performance when used with Isover mineral wool insulation |
| ✓ ACOUSTIC | Excellent acoustic performance when used with Isover mineral wool insulation |
| ✓ MOISTURE | Vapour permeable breathable insulation. Improves energy performance and reduces heating & cooling costs |
| ✓ EASY TO INSTALL | Simple and easy to install. Revolutionary new installation system with Xtra membrane and Xtra tape with apply and release function – no need for staples |

STANDARDS AND CERTIFICATION

| | |
|-----------------------------|---|
| ✓ QUALITY | We hold a Quality Management Standard BS EN ISO 9001: 2008 for manufacturing |
| ✓ CE | All products are manufactured in accordance with the CE marking requirements under the Construction Products Regulation |
| ✓ PRODUCT STANDARDS | All our products are manufactured in accordance with product standard: EN 13162: 2008 and EN 13172 Evaluation of Conformity |
| ✓ ENVIRONMENT | Isover is an ISO 14001:2004 (Environmental Management System) accredited manufacturing facility. This accreditation ensures that all products are manufactured to the stringent standards set out by this management system. EN ISO 13162 EMS 551706 003 EN ISO 9001: 2000 |
| ✓ INDOOR AIR QUALITY | Awarded the highest standard in indoor air quality - Eurofins "Gold Standard" Label. The Gold Certificate means that Isover mineral wool is certified as an outstanding material in terms of Indoor Air Quality emissions regulations |
| ✓ DURABILITY | Fire Performance Euroclass classification of the product is related to the organic content, which cannot increase with time. Thermal conductivity of mineral wool products do not change with time, experience has shown the fibre structure to be stable and the porosity contains no other gases than atmospheric air. (See std EN13162:2012 Annex ZA, Table ZA.1) Will not accelerate corrosion with steel, copper or aluminium. Will not sustain vermin, nor breed or promote fungi or bacteria |



WHERE SHOULD YOU USE VARIO®?

In an era of high fuel bills and concern about energy efficiency, a quality insulation and airtightness system is more important than ever. Superior insulation is the ideal solution – because it's a sustainable, effective and an economical investment. It will help you save on bills and protect the planet too.

Heat lost through the fabric of a building can be substantial, this results in higher fuel consumption in order to maintain comfortable room temperatures, and also substantial energy wastage. Vario®, together with mineral wool insulation, lets you choose whether to make your building an energy liability or an energy asset. Choosing Vario® allows you avoid energy loss and create a sustainable, comfortable home.

So whether you are planning to go with a timber frame, masonry or steel frame construction for a new building or dwelling, select Vario®: the leading, complete high performance intelligent airtightness & moisture control system.

Areas of Heat Loss in Homes (Source: SEAI)

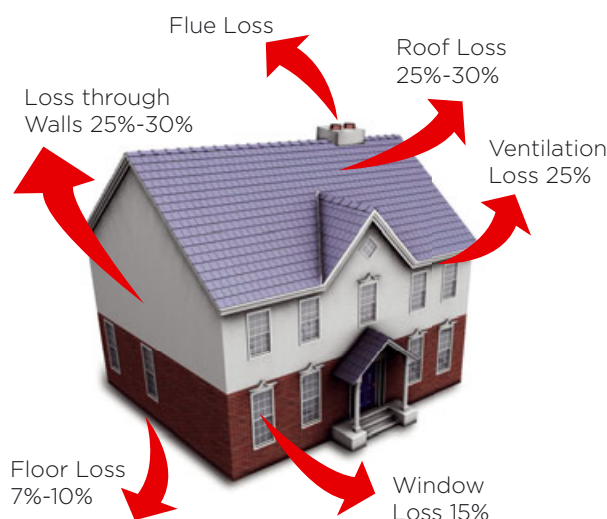

The Vario® system can be used in a diverse range of constructions:

Timber Frame Buildings

On roofs, walls, windows and doors, sealing up any openings or penetrations in the building envelope where heat might be lost.

Masonry Buildings

On roofs, windows, doors and also to seal up any opening or penetrations in the building (such as vents for tumble dryers) where heat can be lost.

Steel Frame Buildings

In steel frame structures such as commercial and retail buildings, Vario® can be used in the same applications as on timber frame structures, except tapes are used instead of staples.

Roofs - Timber Frame, Masonry and Steel Buildings

No matter what type of structure or material forms the frame of your building, your roof can be fitted with Vario®.

Vario® is also an essential tool in fixing any penetration or opening in the roof of your building structure. The flexibility of the Vario® system allows you to achieve airtightness and heat protection by sealing all penetrations and thus the building envelope.

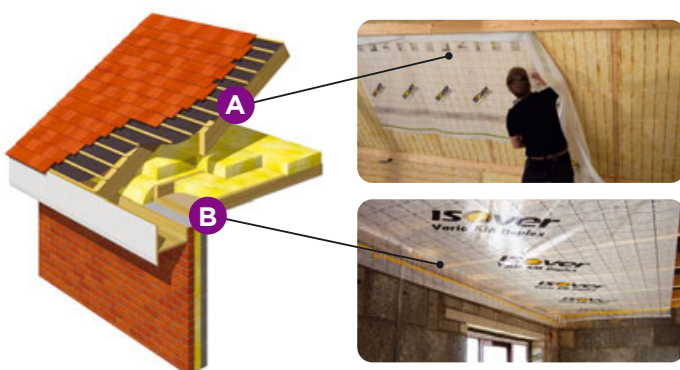

A: Inhabited roof structures

Vario® is stapled to the rafters of the sloping roof on the inside.

B: Uninhabited roof structures

Vario® is stapled to the underside of the joists and sealed to the wall on the inside.



Walls - Timber Frame Buildings

Vario® offers specifiers of timber frame housing a complete solution, as it is the world's most advanced system for the management of interstitial moisture in timber framed construction. Vario® technology is proven, having been extensively tested and specified in high volume timber frame construction in the exacting standards and climates of Northern Europe and Scandinavia.

Specifiers dealing with timber framed buildings start with an advantage in that the Vario® membrane is also an effective air barrier - providing exceptional airtightness for the building envelope.

Another unique quality of Vario® is its ability to protect the inside of the building and its occupants against toxic gases, which may emanate from chemical preservatives contained within the timber structure. This is particularly important when converting the attics of older buildings into living space, as the type and toxicity of any preservatives can be unknown and therefore potentially hazardous.

The Vario® system of membranes and tapes is used to wrap and seal the outer walls (by stapling to the studs), windows, doors and all penetrations of the building envelope.

Walls - Masonry Buildings

The Vario® system is also the optimum solution for masonry construction. Selecting Vario® as your membrane of choice provides exceptional airtightness of the building envelope when applied to the sealing of windows and doors, timber roof structures, and the sealing of separating timber floors to block walls and of all penetrations throughout the masonry building envelope.

The Vario® membrane is stapled to the underside of joists below the attic and then sealed to walls. Where separating timber floors join outer block walls, Vario® tapes are used to seal potential leaks.

Walls - Steel Frame Buildings

In commercial and retail buildings, Vario® can be used in much the same way as on timber frame structures: sealing the outer walls on the warm side, windows, doors and all penetrations of the building envelope.

The flexibility of the Vario® system allows you to achieve the highest standards of airtightness and heat retention in any size commercial and retail building.

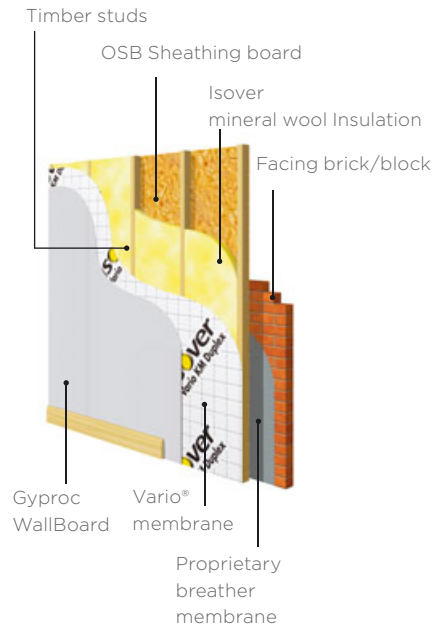

The Vario® membrane is sealed to masonry walls at ceiling level. Vario® Tape (in the above images, Vario® Bond) is used to seal the point where timber separating floors penetrate the outer blockwork and where windows meet blockwork.

Penetrations and Openings

One of the most common ways to compromise your building's overall airtightness and heat retention is to fail to address penetrations. This can be easily remedied with the Vario® System.

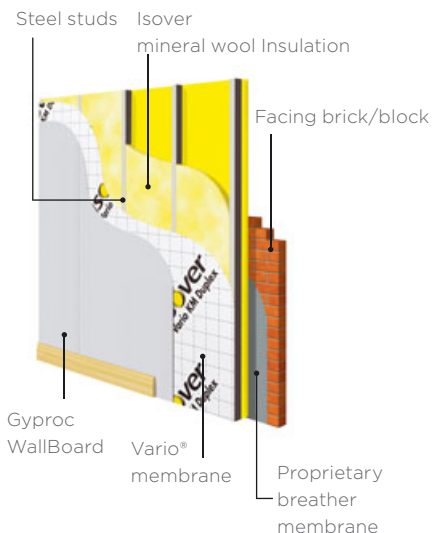

DON'T SWEAT IT

BUILDINGS BREATHE BETTER WITH ISOVER VARIO



THE HIGH PERFORMANCE SYSTEM

ISOVER Vario® is a high performance system consisting of intelligent membranes (Vario KM Duplex & Xtra) and Vario accessory tapes and mastic which provide:

- **PROTECTION FROM DAMP AND DAMAGE**
- **WARMTH IN WHILE KEEPING MOISTURE OUT**
- **IMPRESSIVE VARIABLE SD VALUE**

Contact our technical team:
ROI: **1800 744 480** NI: **0845 399 0159**
tech.ie@saint-gobain.com
Visit **www.isover.ie/vario** to learn more

 **isover**
SAINT-GOBAIN



A QUICK GUIDE TO WHAT, WHERE AND HOW TO USE THE VARIO® SYSTEM



Vario® KM Duplex UV Membrane

The heart of the Vario® System: our patented polyamide membrane acts like a sensitive skin.



Isover Metac

The Metac innovative multi-application high performance thermal roll – our finest thermal insulation product.



Vario® KB1

Our high adhesion, single-sided tape provides wind and airtight adhesion of Vario® membrane for horizontal and vertical overlapping, which now features water resistant glue and measurements on the tape to make installation easier.

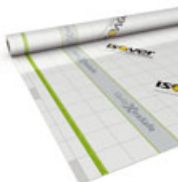

Vario® Xtra

The Intelligent membrane for greater safety.



Vario® MultiTape SL+

A non-ageing tape, featuring extremely high adhesion for sealing overlapped membrane joints and – crucially – sealing effectively around any installation gaps, which also features water resistant glue. Available in 60mm and 150mm widths to suit narrower or wider cavities.

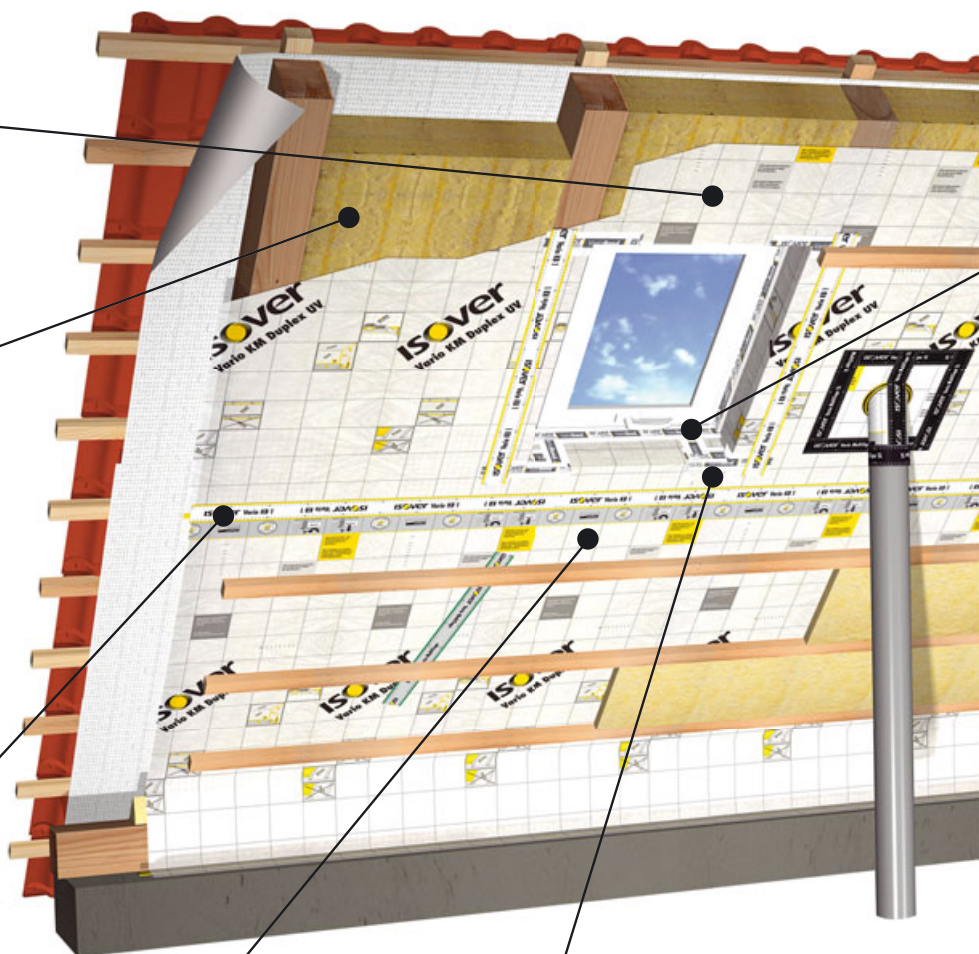

**VarioBond**

A High Performance Airtight Plasterable, Junction Tape For Windows, Doors and Timber to Block Connections.

Key Features:

- ✓ Multi-application for internal & external use*
- ✓ Plasterable – can be plastered or rendered over with Gypsum based undercoat plasters, sand and cement and exterior renders
- ✓ Vario® Bond has a high adhesive strength, which bonds to a number of substrates
- ✓ Pre-split, with finger-lift function for easy installation
- ✓ Airtight, windtight and driving rain proof

SUBSTRATES

- ✓ Vario® Membrane
- ✓ Timber
- ✓ PVC
- ✓ Concrete Block
- ✓ Metal & Concrete Lintels
- ✓ PVC Cavity Closers

JUNCTIONS

- ✓ Timber wall plate
- ✓ Internal Windows
- ✓ External Windows
- ✓ Internal Floors

**Vario® DoubleFit+**

Universal sealant - a 2-in-1 solution for creating air-tight joins between vapour membrane and adjacent surfaces.

Find more Vario® applications online at
www.isover.ie

* The surface on which the tape is installed must be free from releasing film (e.g., moisture, ice or hoar frost) which would prevent contact of the adhesive with the surface.



New Build U-Values:

0.16 Pitched Roof

Renovation U-Values:

0.25 Pitched Roof

BUILDING REGULATIONS REPUBLIC OF IRELAND

The following is a guide to thermal building regulations for new & existing dwellings, delivering comfort and energy savings through effective thermal insulation.

Republic of Ireland

New Dwellings TGD - Part L - 2022

Minimum standards for U-Values

Upper limit for air permeability is $5\text{m}^3/(\text{h.m}^2)$

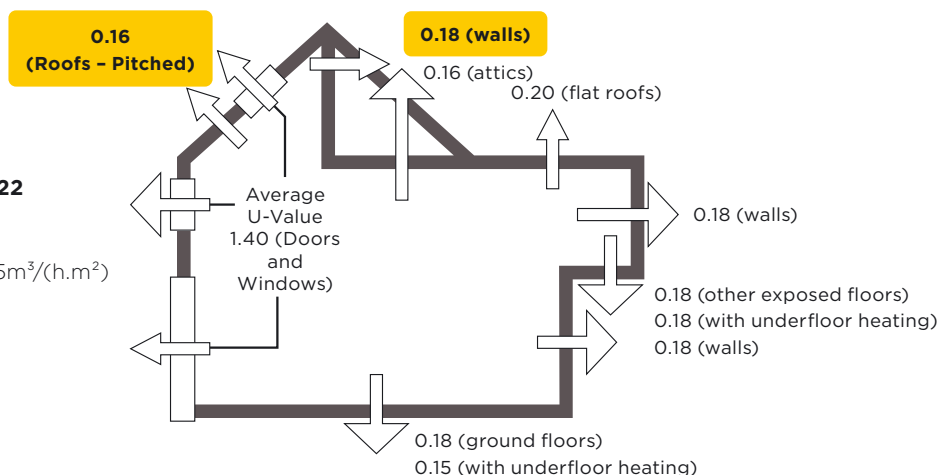

For more information you can contact our technical team on free phone (ROI) 1800 744480 or go to www.isover.ie

Republic of Ireland

Existing Dwellings TGD - Part L - 2022

Minimum standards for U-Values

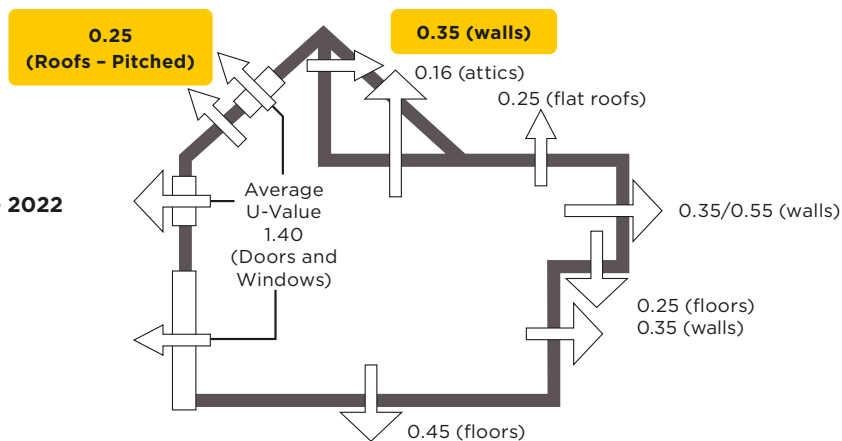

For more information you can contact our technical team on free phone (ROI) 1800 744480 or go to www.isover.ie



Contact our technical team for more info

ROI
1800 744480

NI
0845 399 0159

EMAIL
tech.ie@saint-gobain.com

*New Build U-Values:***0.20 Pitched Roof***Renovation U-Values:***0.18 Pitched Roof**

BUILDING REGULATIONS NORTHERN IRELAND

The following is a guide to thermal building regulations for new & existing dwellings, delivering comfort and energy savings through effective thermal insulation.

Northern Ireland

New Dwellings – DFP Technical Booklet F1:2012

Minimum standards for U-Values

Upper limit for air permeability is $10\text{m}^3/(\text{h.m}^2)$

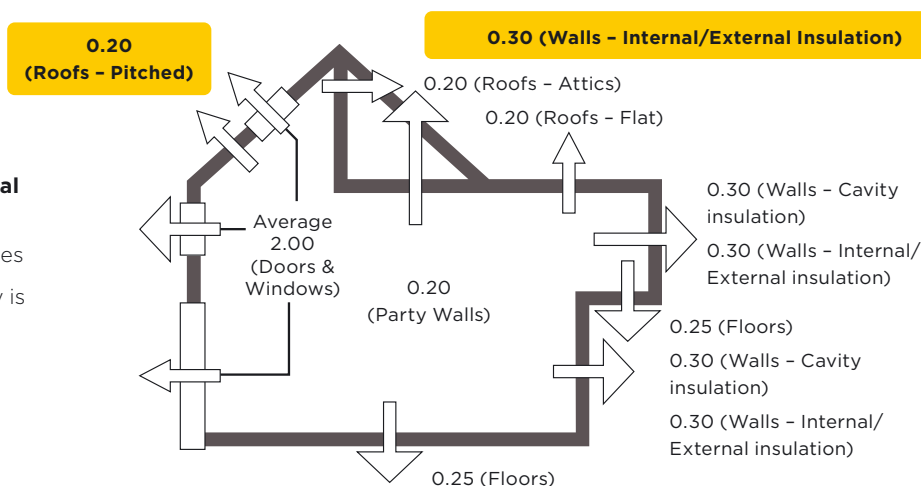

For more information you can contact our technical team on phone (NI) 0845 339 0159 or go to www.isover.ie

Northern Ireland

Existing Dwellings – DFP Technical Booklet F1:2012

Minimum standards for U-Values

These regulations are split across new thermal elements added to an existing dwelling, for example a new extension or dormer & upgraded thermal elements within the existing building.

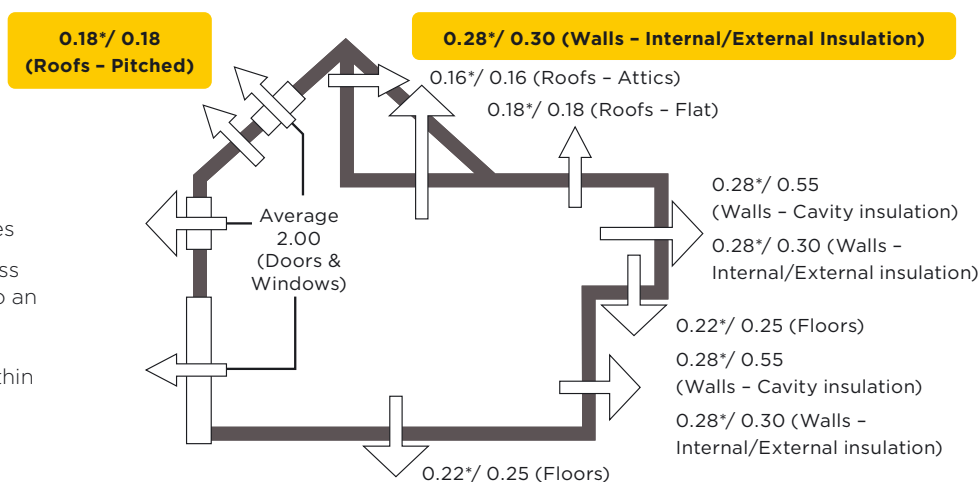

*figures refer to a new element added to an existing dwelling i.e. extension, dormer etc.

For more information you can contact our technical team on phone (NI) 0845 339 0159 or go to www.isover.ie



ISOVER VARIO® SYSTEM

A high performance system consisting of intelligent membranes and accessory products, providing excellent levels of airtightness with unparalleled protection against moisture.

Product Features

- ✓ High performance airtightness and moisture control system
- ✓ Two intelligent membranes to suit a variety of applications
- ✓ Range of accessory products – high performance tapes and sealants

**High performance
airtightness &
moisture control**



Where to use



Walls – Internally



Roof – Internally



Floors – Internally

ISOVER VARIO® SYSTEM

For use in Airtightness applications



High performance membranes with accompanying accessories unique in providing excellent levels of airtightness.



VAPOUR
PERMEABLE
INSULATION



CONTRIBUTES TO
ENERGY SAVINGS



MINIMAL
WASTE





EASY TO
TRANSPORT



EASE OF
HANDLING &
INSTALLATION







Intelligent Variable Sd Membranes

| Product | Order Code | Width (mm) | Length (m) | M ² Per Roll | Pack | Packs Per Pallet | |
|---------------------------|------------|------------|------------|-------------------------|--------|------------------|---|
| Vario® Xtra Membrane | 5200814933 | 1500 | 40 | 60 | 1 Roll | 42 Rolls |  |
| Vario® KM Duplex Membrane | 5200300299 | 1500 | 40 | 60 | 1 Roll | 42 Rolls |  |

Fixed Sd Membranes

| Product | Order Code | Width (mm) | Length (m) | M ² Per Roll | Pack | Packs Per Pallet | |
|------------------------|------------|------------|------------|-------------------------|--------|------------------|---|
| Vario StopVap Membrane | 5200815577 | 1500 | 40 | 60 | 1 Roll | 46 Rolls |  |

Airtightness Tapes & Mastic

| Product | Order Code | Width (mm) | Length (m) | M ² Per Roll | Pack | Packs Per Pallet | |
|-----------------------------|------------|------------|------------|-------------------------|---------------|---------------------------|---|
| Vario KBI Single Sided Tape | 5200300297 | 60 | 40 | 2.4 | 5 Rolls | 120 Boxes (600 Rolls) |  |
| Vario MultiTape SL+ | 5200431017 | 60 | 25 | 1.5 | 10 Rolls | 80 Boxes (800 Rolls) |  |
| Vario MultiTape SL | 5200916780 | 150 | 25 | 3.75 | 10 Rolls | 24 Boxes (240 Rolls) |  |
| Vario DoubleTwin | 5200678235 | 19 | 50 | 0.95 | 15 Rolls | 48 Boxes (720 Rolls) |  |
| Vario Bond | 5200683153 | 100 | 25 | 2.5 | 6 Rolls | 48 Boxes (288 Rolls) |  |
| Vario Bond | 5200683156 | 150 | 25 | 3.75 | 4 Rolls | 48 Boxes (192 Rolls) |  |
| Vario Doublefit+ Mastic | 5200645927 | N/A | 310ml | N/A | 12 Cartridges | 75 Boxes (900 Cartridges) |  |



ATTICS

Twin Leaf Construction

1. Isover insulation between joists
2. Second layer of Isover insulation cross laid over joists
3. Isover insulation installed between rafters
4. Vario® System

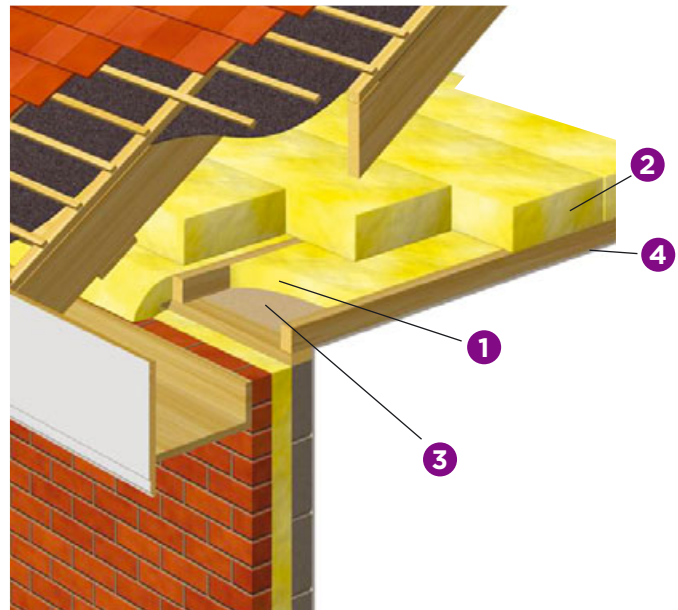

Application CAD Details

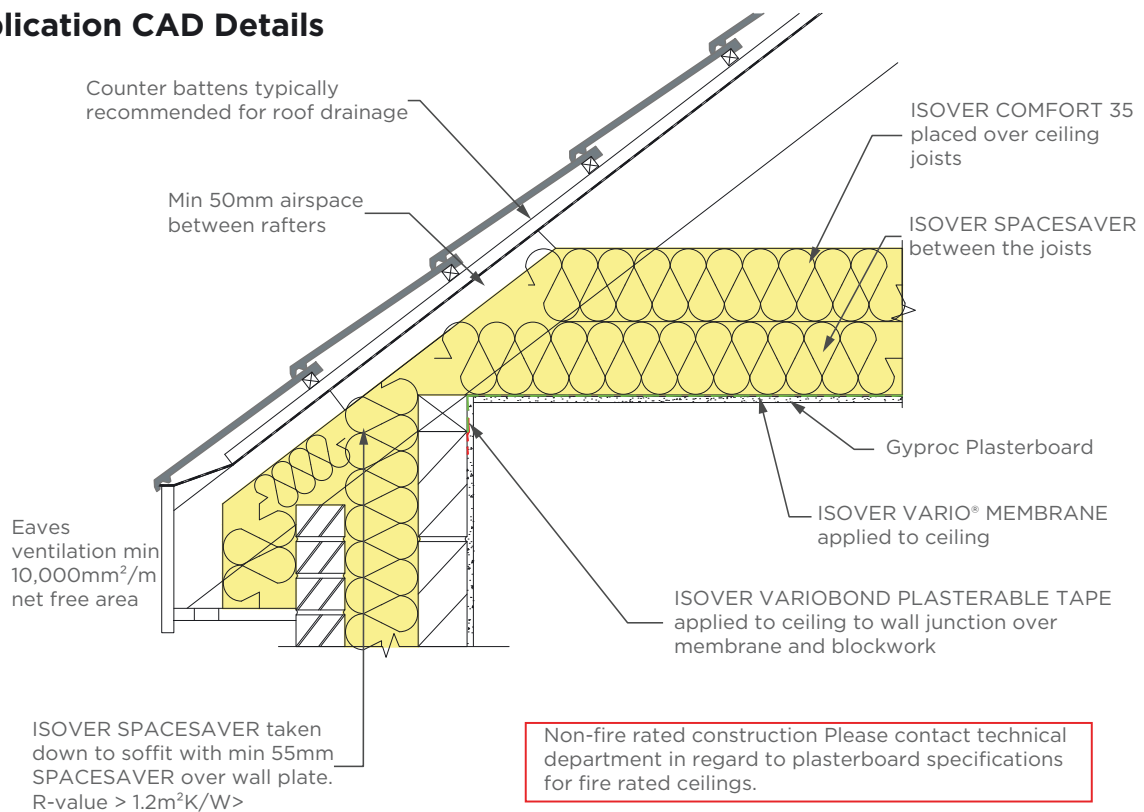

Isover Products



Spacesaver Roll



Comfort 35 S



Vario® System



PITCHED ROOFS

Insulation between rafters

1. Tiled or slated roof on tiling battens
2. Low resistance underlay
3. Isover insulation installed between rafters
4. Vario® membrane + tapes
5. 12.5mm Gyproc WallBoard

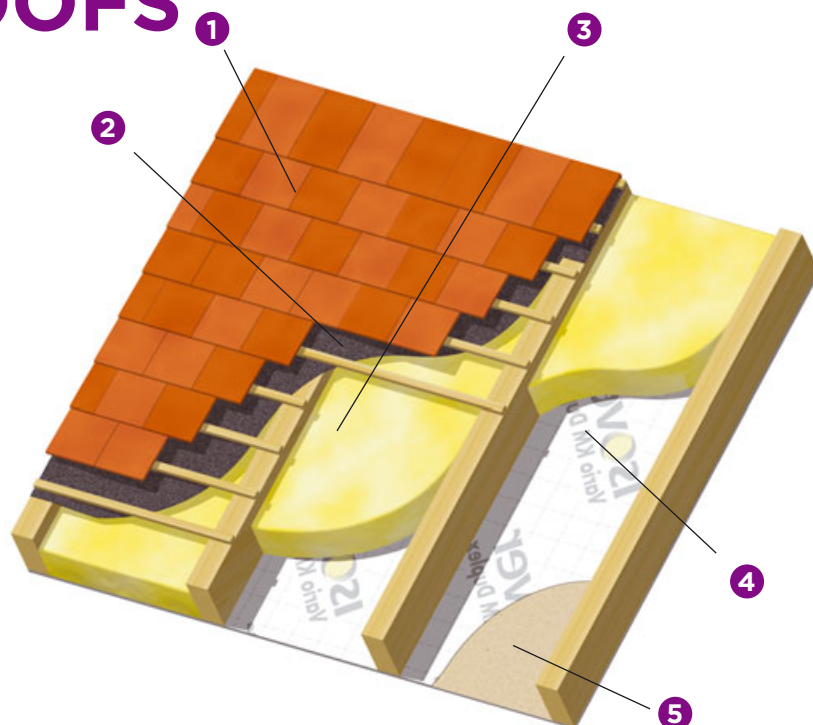

Application CAD Details

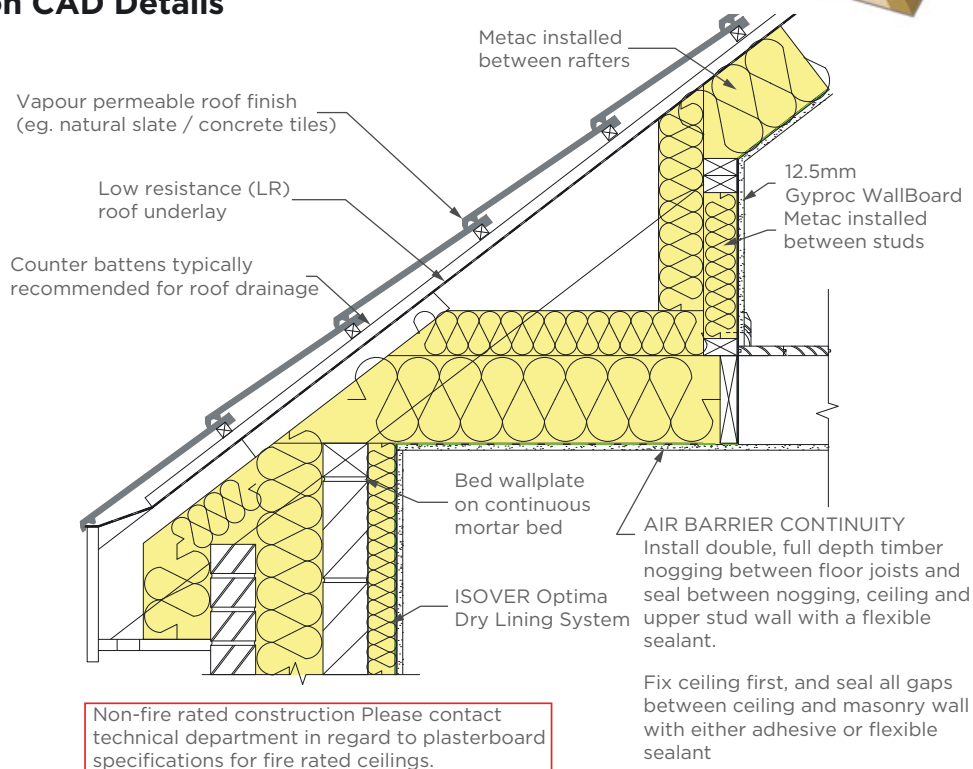

Isover Products

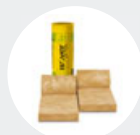

Metac Roll



Vario® System



PITCHED ROOF WITH INTERNAL COUNTER BATTENS

Insulation full filled between rafters + Vario® + internal counter battens

1. Tiled or slated roof with external counter battens/ventilation space*
2. Low resistance Underlay per BS 5250
3. Isover insulation installed between rafters
4. Vario® System
5. Isover insulation between counter battens
6. Gyproc WallBoard

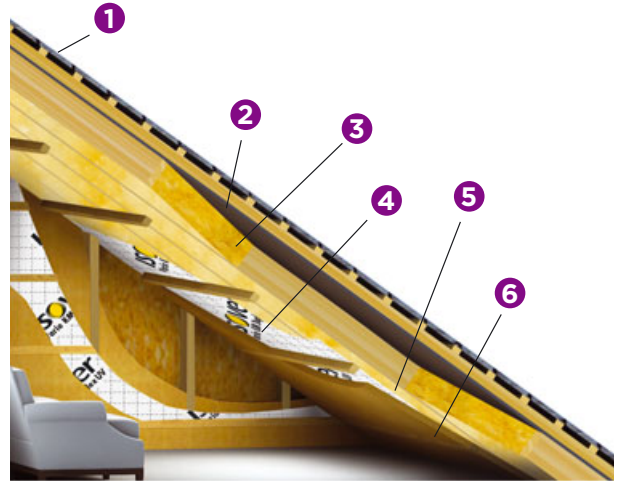

*even in instances where there is a non-permeable roof finish (fibre cement slates) and no external counter batten/ventilation space Metac can still be full filled once used with Vario® Xtra. Contact our Technical team for more information.

Application CAD Details

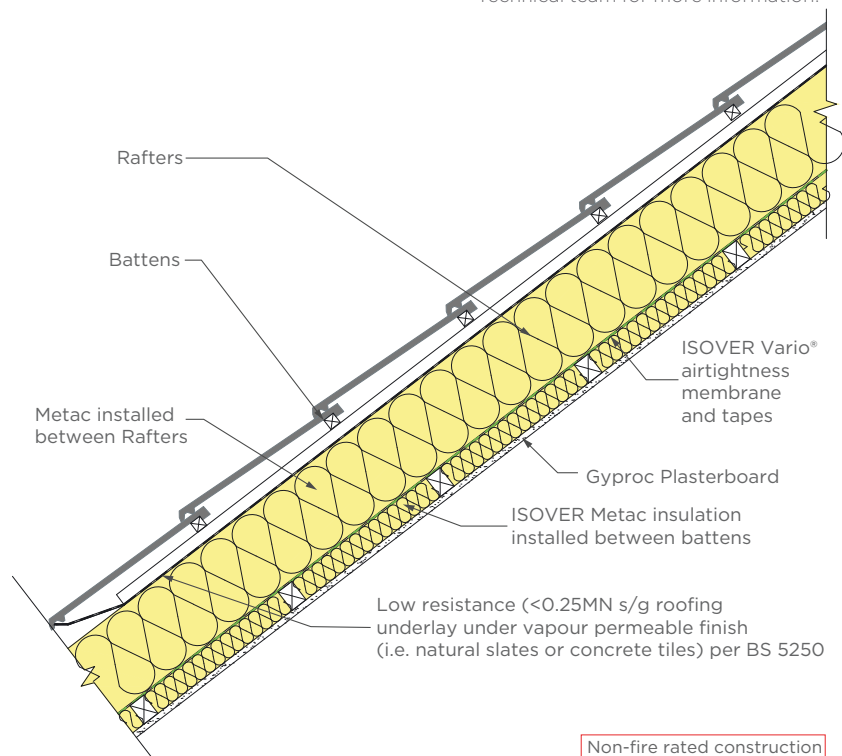

Isover Products



Metac Roll



Vario® System



TECHNICAL ACADEMY

With purpose built facilities, dedicated resources in Kingscourt and Dublin as well as NEW Online Training, Saint-Gobain Technical Academy offers a wide range of FREE training courses and webinars to upskill and educate construction industry professionals.

The mix of interactive training, live demo and theory courses include:

- Airtightness and moisture management
- Acoustics in Buildings
- Dry lining systems for installers and supervisors
- nZEB in Practice
- Fire performance in buildings
- Renovation solutions
- ROI Building Regulations & Compliance
- Internally insulating existing external walls: The challenges faced and a possible solution

...and much more

Sign up for our NEW Online Training Courses at

www.saint-gobain.ie



REGISTER NOW

**Sign Up
TODAY!**

Get the **know-how** with the **Saint-Gobain Technical Academy**



SAINT-GOBAIN



DRY LINING

Multiple Substrates / Construction Types

1. 215 mm brick
2. 13mm Gyproc Plaster
3. Optima metal studs + fixings
4. Isover insulation
5. Vario® membrane + tapes placed on studs
6. Gyproc WallBoard



Hollow block wall to intermediate floor junction

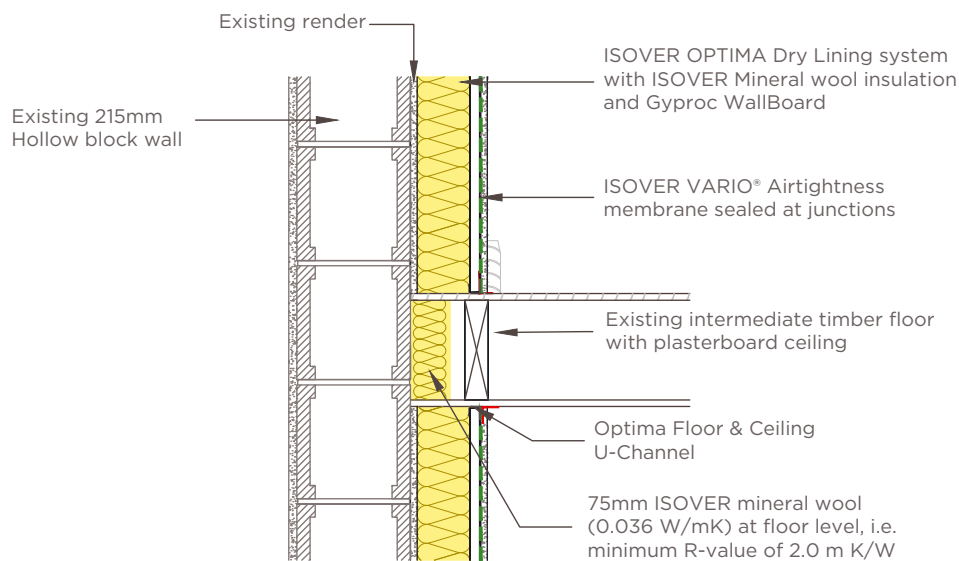

Existing floor boards to be cut back where possible to accommodate installation of VARIO® membrane through intermediate floor on room side of insulation, lapped and sealed above/below

Isover Products



Optima Dry Lining System

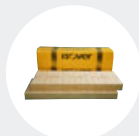

Comfort Panel 32

OR



Comfort Roll 35 S

OR

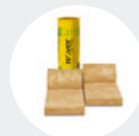

Metac



Vario® System



Hollow block wall to ground floor junction

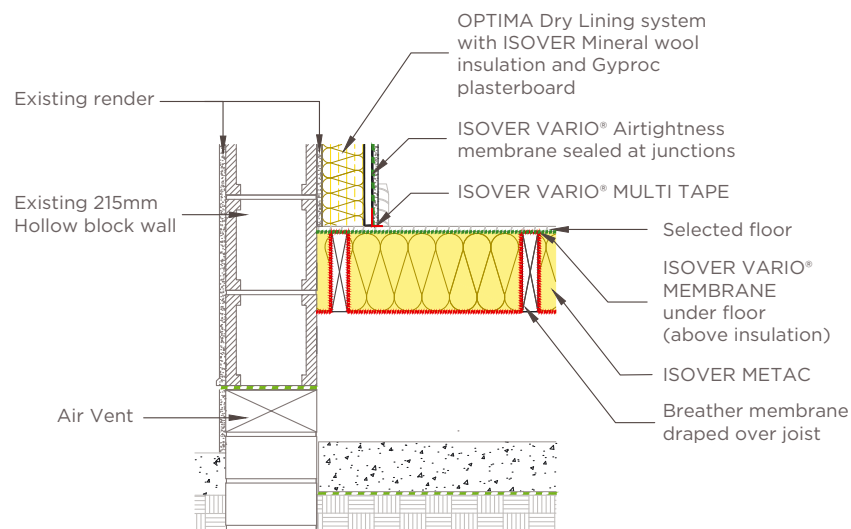

Wall to attic junction

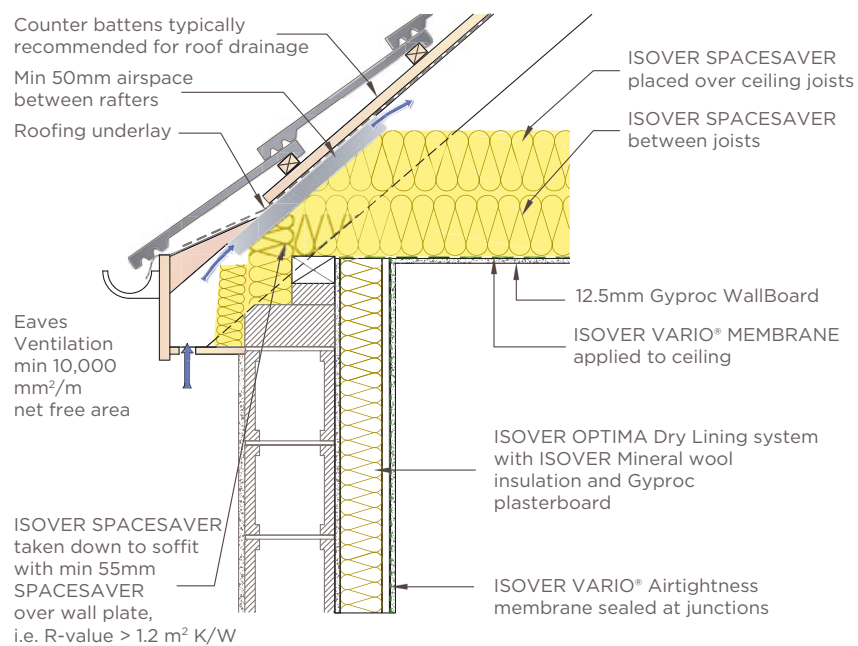

Masonry wall to ground floor junction

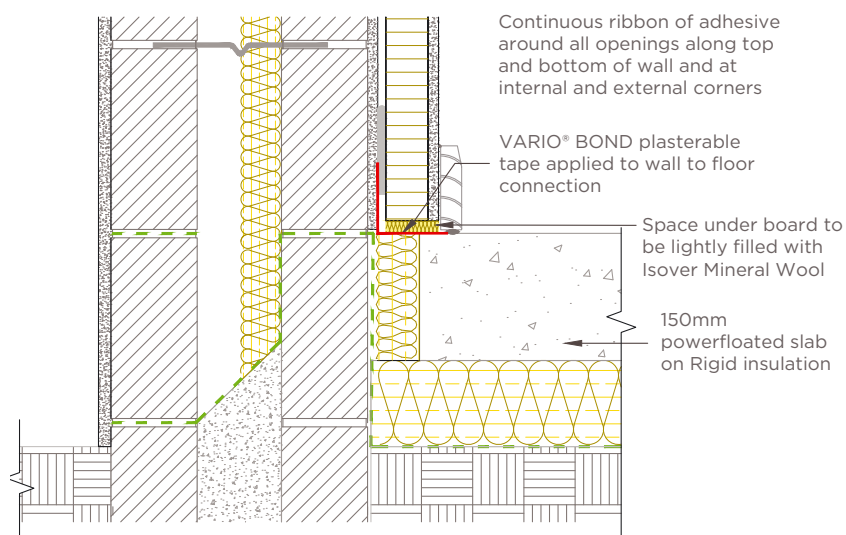



TIMBER FRAME WALL

Insulation between studs

1. Brick Outer Leaf
2. Cavity 25mm secured with wall ties
3. Breather membrane on OSB affixed to timber studs on the cavity side of the build up
4. Isover Insulation Metac O31 140mm friction fit between 600mm studs
5. Isover StopVap or KM Duplex Airtightness Membrane affixed to inside of timber studs. Joints of membrane sealed to each other with Vario® Airtightness tapes and accessories
6. HD Slab, affixed to the rafters using full height battens, running parallel to the studs of the external wall
7. Batten with 50mm Service Cavity
8. Gyproc Plasterboard
9. Gyproc Plaster Finish

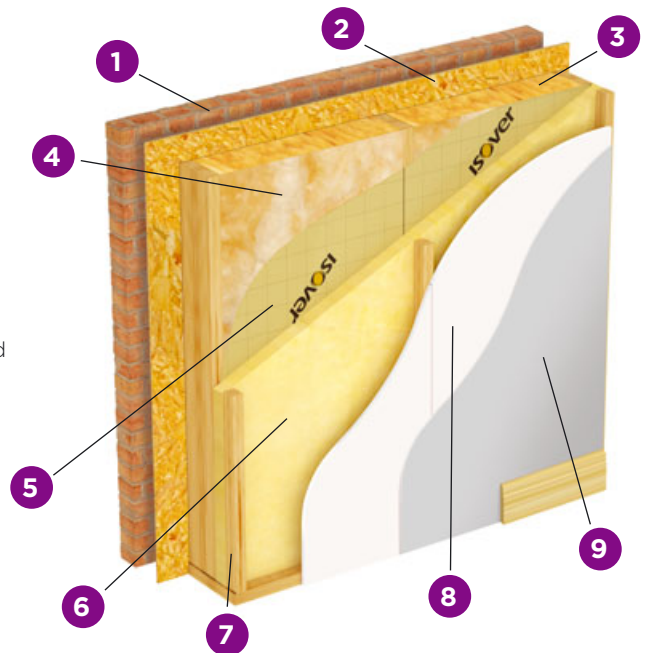

Application CAD Details

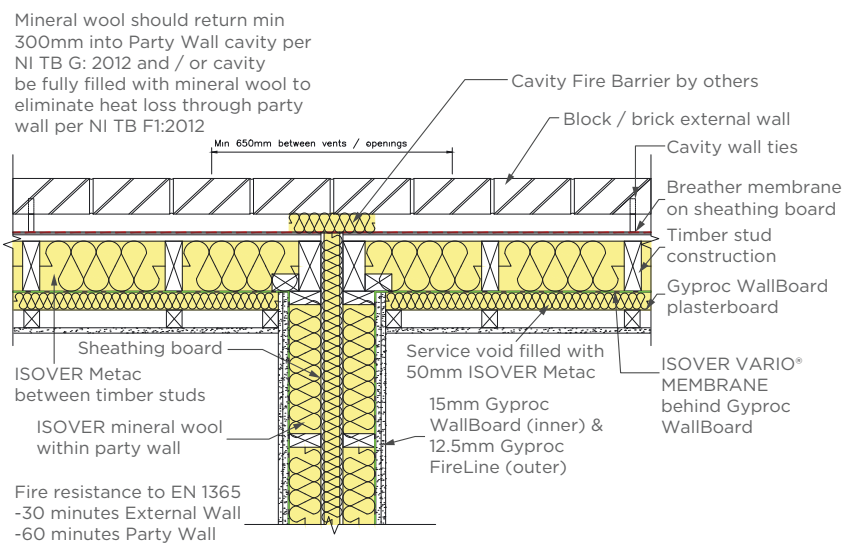

External Wall 2 layers of 12.5mm Gyproc FireLine required on external wall for buildings with separating floors or requiring 60 minutes fire rating (to EN test standards)

Isover Products



Comfort Roll 35 S

OR



Metac

OR

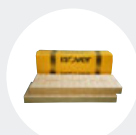

Comfort Panel 32

+



Vario® System



Insulation fully filled between rafters with Vario® and Isover InLiner board

1. External brick
2. 50mm clear cavity
3. Breather membrane + Sheathing board
4. Isover insulation between studs
5. Vario® membrane + tapes
6. Isover insulation between counter batten
7. Gyproc Plasterboard

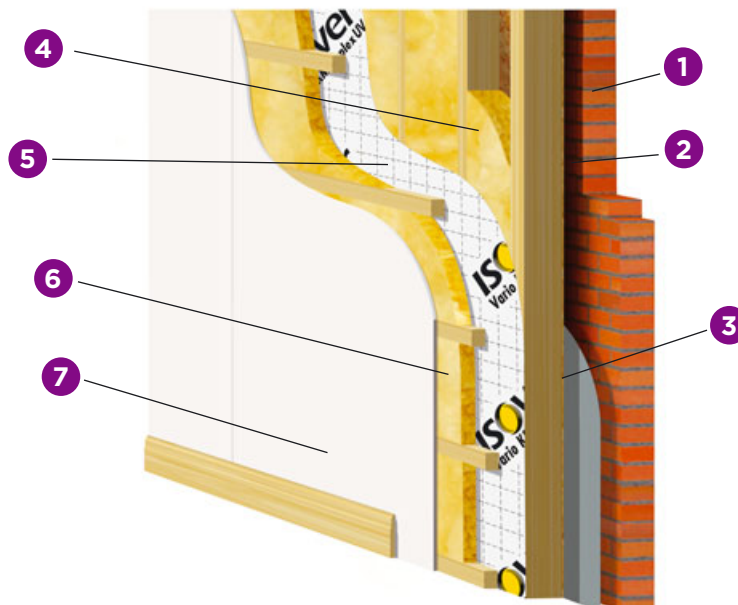

Application CAD Details

Mineral wool should return min 300mm into Party Wall cavity per NI TB G:2012 and/or cavity be fully filled with mineral wool to eliminate heat lost through party wall per NI TB FI:2012

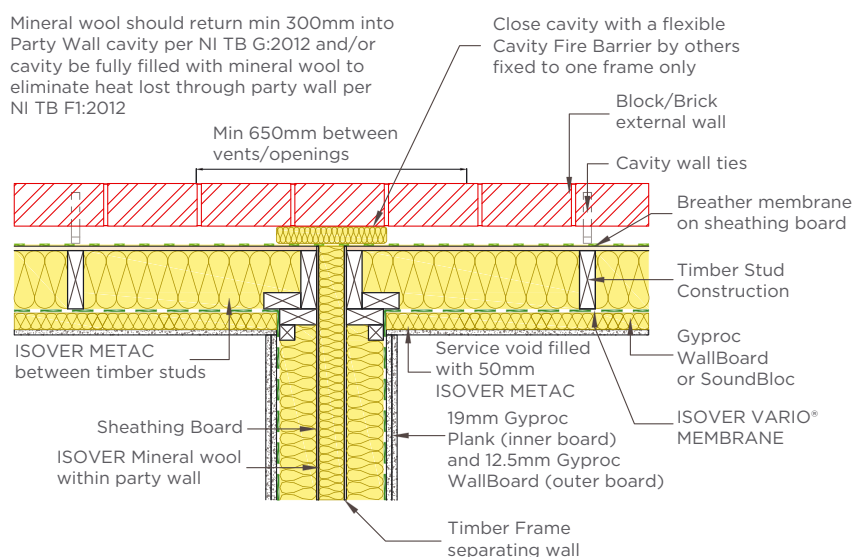

External Wall

2 layers of 12.5mm Gyproc FireLine required on external wall for buildings with separating floors or requiring 60 minutes fire rating (to EN test standards) Est. lab sound insulation 100-3150 Hz: Airborne 50-55 RwdB

Isover Products



Comfort Roll 35 S

OR

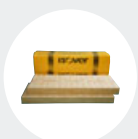

Comfort Panel 32

+

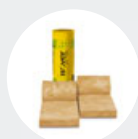

Metac

+



Vario® System



METAL STUD SEPARATING PARTY WALL

Twin leaf construction Overall construction nominal width 250mm

1. 2 x 15mm Gyproc SoundBloc
2. Isover Vario® membrane + tapes
3. Two frameworks of Gypframe 60 I 50 'I' Stud at 600mm centres
4. Isover Acoustic Roll in the cavity

Application CAD Details

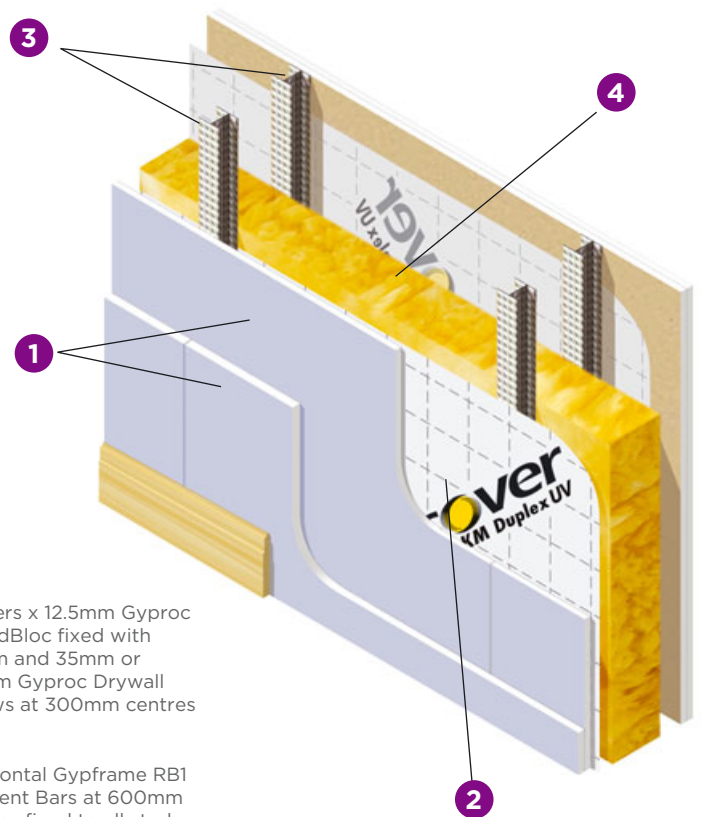
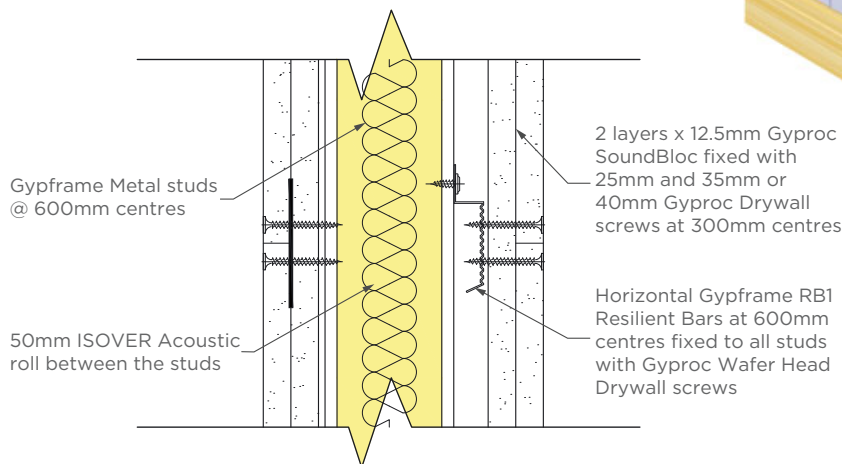

Isover Products

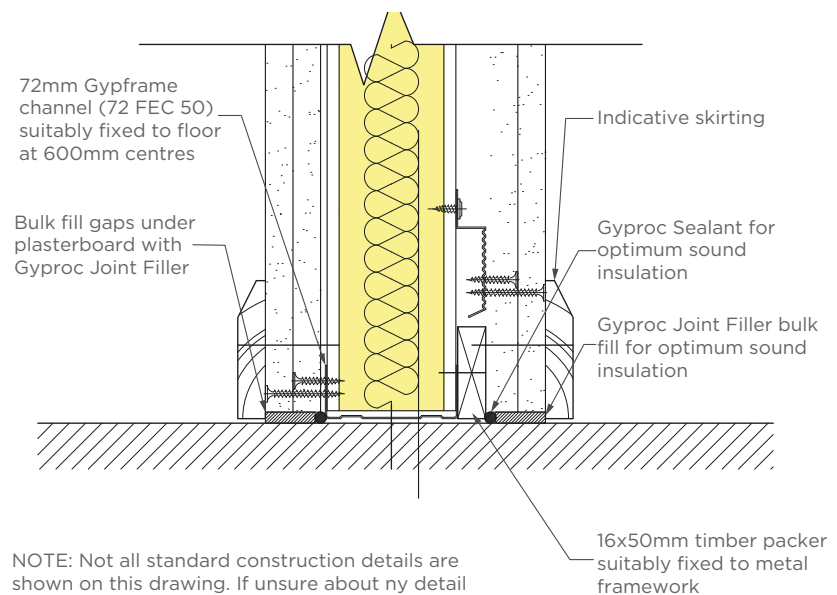
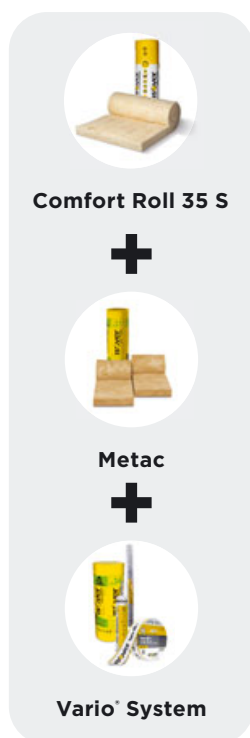



SUSPENDED GROUND FLOOR

Timber – Insulated between joists

1. Timber walking surface
2. Vario® membrane + tapes
3. Isover insulation between joists
4. Breather membrane / netting
5. Ventilated void
6. Ground floor slab

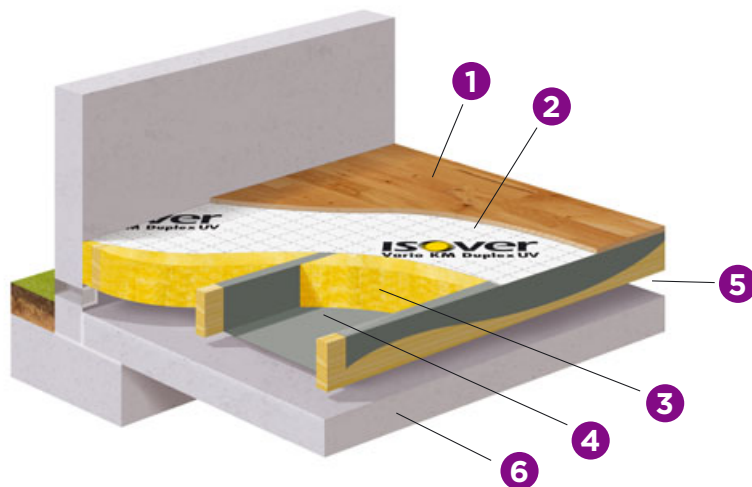

Application CAD Details

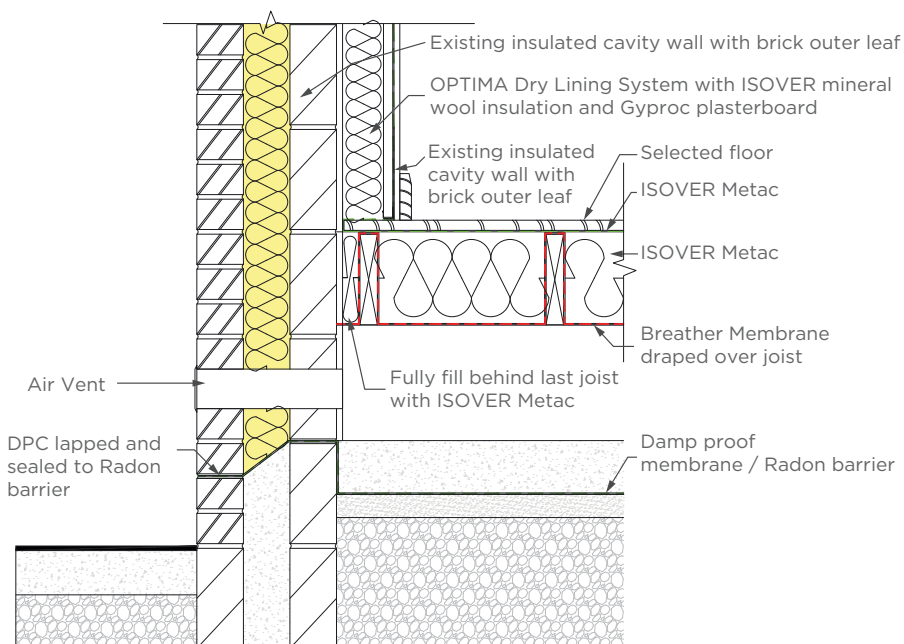

Isover Products



Spacesaver Roll

OR



Metac

+



Vario® System



CASE STUDY

**111 Central Promenade,
Newcastle County Down**

Project Overview

Category: Retrofit

Duration: 8 months

Contractor/Specifier: CHP Mechanical and Liam Milling Architects

Size: 600m²

Project Goal

The aim of the project was to convert two early 20th century houses into 7 contemporary apartments for the popular seaside town of Newcastle. The owner required a high spec finish and we had to consider the external fabric of the buildings to enable Isover to come up with a suitable system that would work with the existing buildings.

Project Challenge

Due to the age of the houses there was some concern as the external walls were leaking water. The fact the external walls were wet, required a system that would give the owner durability, moisture management, airtightness, robustness, an upgrade in thermal, acoustic performance and adaptable to suit the building.

How did you overcome these challenges?

At the first site meeting, Mark McCormick raised concerns that the wall lining on the plans would cause moisture in the external walls to become trapped and over time cause issues. We then put forward our Isover Optima system, and when Liam the architect checked everything out he decided to change the plans to use Isover's Optima Dry Lining System.

What challenges were unique about this build?

The age of the building and the high spec finish of the apartments which would allow the apartments to be used all year round.

How did you overcome these unique challenges?

We produced U-Value reports and condensation analysis which showed that we delivered the required U-Value, allowed the walls to breathe, had an excellent airtightness level, was robust and gave a greater level of acoustic performance.

U-value achieved:

**EXTERNAL
WALLS**

0.20

Isover Products



**Optima Dry Lining
System**



Metac



Acoustic Roll



Spacesaver Roll



Spacesaver Plus



Vario System





Isover Ireland

Unit 4, Kilcarbery Business Park,
Nangor Road, Dublin 22
D22 R2Y7
Telephone: 01 629 8400
Email: info@isover.ie
www.isover.ie



@SaintGobainGroup



Saint-Gobain



@saintgobain

Gyproc, Gypframe and Glasroc are all registered trade names of Saint-Gobain Construction Products (Irl) Limited. Isover is a registered trade name of Saint-Gobain. Saint-Gobain Construction Products (Irl) Limited reserves the right to revise product specifications without notice. The information in this document was correct to the best of our knowledge at the time of publication. It is the user's responsibility to ensure that it remains current prior to use. The information in this document is for guidance only and should not be read in isolation. Users should read and familiarise themselves with all the information contained in this document and ensure that they are fully conversant with the products and systems being used, before subsequent specification or installation. For a comprehensive and up-to-date library of information visit the Isover website at: www.isover.ie